

| | |
|--------------|-------------------------------|
| Vehicle Type | For Concrete Pumping Vehicles |
| Gearbox Type | - |

| | |
|-------------------|------------------|
| Product Code | UARA.2401 |
| Revision No- Date | 01 / 10.07.2017 |

Product Views

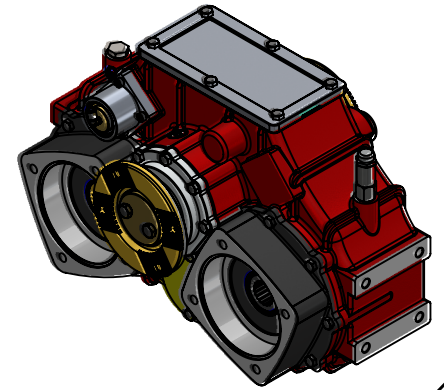
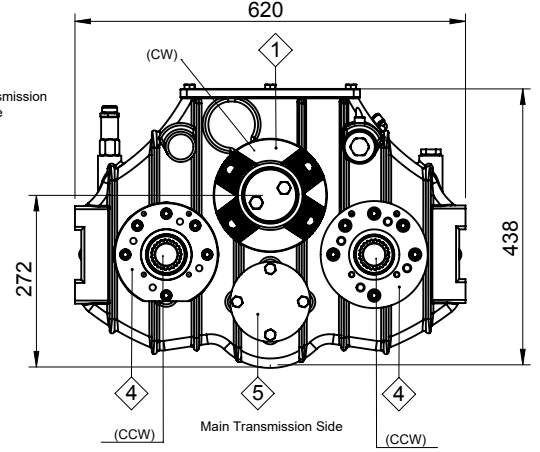
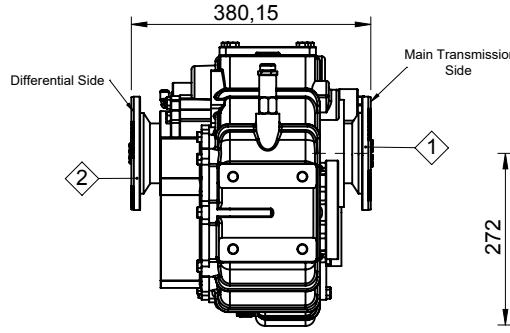
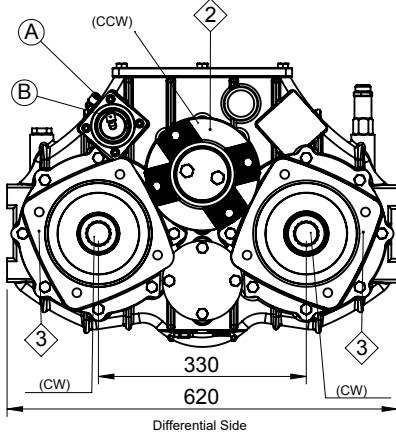

- ① ISO 7647 - ISO 7646 - ISO 8667 Standard Flange
- ② ISO 7647 - ISO 7646 - ISO 8667 Standard Flange
- ③ Concrete Pump Output (Z:18 DIN 5480)
- ④ Pump Output: 2P1, Gear Pump
- ⑤ Pump Output: 1P1,2P1, Gear Pump
- A: Air Inlet R1/4" (Rear Axle Output Engage-Pumps Output Disengage)
- B: Air Inlet R1/4" (Rear Axle Output Disengage-Pumps Output Engage)

Technical Details

| Input/Output | Maximum Values | Input/Output Ratio | Sense of Rotation | Mounting Type | |
|--------------|----------------|--------------------|-------------------|---------------|---------------|
| ① | 3000 kgm | - | - | Split Shaft | |
| ② | 3000 kgm | 1/1 | - | | |
| ③ + ④ | 160 kW | 1/1,25 | - | Weight | Body Material |
| ⑤ | 75 kW | 1/1,7 | - | 195 kg | Sfero/NCI |

- Kozmaksan Şirketi katalogta verilen bilgileri önceden bildirmeden değiştirme hakkını saklı tutar. Bu belge genel bilgiler içerir ve taahhüt ve sözleşme niteliğinde değildir.
All content contained herein is subject to change without notice.
This is not a legally binding document. It is for information only.
- Verilen güç ve tork bilgileri sadece PTO/ara şanzımana aittir. Uygulama yapılacak şanzıman, motor ve aracın PTO/ara şanzıman için uygun görüldüğü değerleri aşmayınız.
Maximum power and torque limits provided are only valid for the mentioned PTO. Do not exceed the PTO power and torque limits determined by the transmission and the vehicle manufacturer.
- Şanzımana civata ile bağlanan PTO'lara takılacak pompa, şaft vb. parçaların ağırlık ve askıda kalan uzunlukları şanzıman ve araç üreticisinin onayladığı limitleri geçmemelidir.
For PTO's coupled rigidly to the transmissions, supported weight and the length of the attached pump, shaft etc. should not exceed the limits provided by the transmission and the vehicle manufacturer.



Ofis / Office
Tel. +90 312 354 05 39
Fax +90 312 354 34 59
7. Sokak No: 9
Ostim / ANKARA
e-mail: info@kozmaksan.com.tr

Fabrika / Factory
Tel. +90 312 267 39 71
Fax +90 312 267 38 72
AOS. 1. OSB. Erkunt Cad. No: 6
Sincan / ANKARA
Website: www.kozmaksan.com.tr